

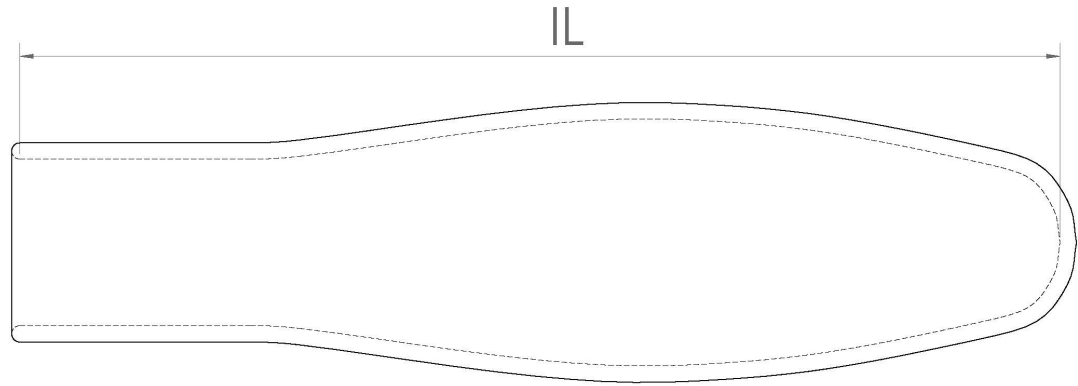

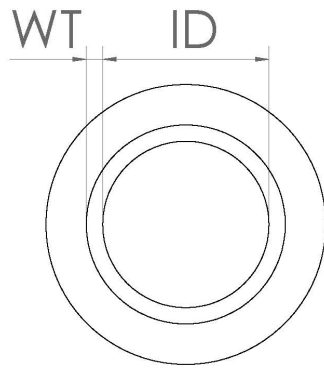

REV	DESCRIPTION	DATE	BY	APP



	<h2>Sinclair & Rush</h2> <p>Global Manufacturer of Plastic, Rubber & Foam Components</p>		<p>SINCLAIR AND RUSH LTD. 19 LAKER ROAD, ROCHESTER KENT, ME1 3QX UK WWW.SINCLAIR-RUSH.CO.UK</p>	
	<p>THIS DRAWING CONTAINS CONFIDENTIAL INFORMATION OF SINCLAIR AND RUSH LTD. AND IS NOT TO BE COPIED, USED OR, DISCLOSED TO OTHERS WITHOUT THE EXPRESS WRITTEN CONSENT OF SINCLAIR AND RUSH LTD.</p>			
<p>THE VINYL DIP MOLDING PROCESS RESULTS IN VARYING WALL THICKNESS. WALL THICKNESS IS MEASURED AT SPECIFIED POINT ONLY.</p>	<p>ALL DIMENSIONS AND SYMBOLS CONFORM TO ANSI Y14,5</p>		DRW	DATE
	<p>THIRD ANGLE PROJECTION</p> 		CK	DATE
			APP	DATE
<p>SCALE</p>				
DESCRIPTION				
SIZE	A	SHEET	1 OF 1	PART / DRAWING NUMBER
				REV 0